

PAINT ELEVATION - FLOOR

- MATTE FINISH
- DOUBLE CHECK LABELING AS FLOOR IS INSTALLED
- ASSUME ALL SHEETS ARE 4'-0"x8'-0"
- ROW K IS BLACK
- THE OFFSTAGE 4'-0" OF COLUMNS 1 & 8 ARE BLACK
- USE 2" PAINTERS TAPE FOR ALL OF THE MORTAR



Disclaimer:
 Drawings are only meant to illustrate ideas and are not intended to be used for construction. The designer does not assume any liability for structural integrity in the design. The company selected to build the design will assume all liability to its structural integrity and related consumer, crew and performer safety.

Brandon M. Newton
 Scenic Designer Signature

Venue: **Jeanine Larson Dobbins Conservatory**
 Stage: **Bedell Theatre**
 Director: **Kitt Lavoie**
 Charge Artist: **Brandon M. Newton**

GUYS & DOLLS

Sheet Title: **Paint Elevation - Floor**
 Date: **June 7, 2021**
 Scale: **1/8" = 1'-0"**
 Designer: **Brandon M. Newton**
 Drawn By: **Brandon M. Newton**

PAINT ELEVATION - MANHOLE COVER
 - START WITH METALLIC BASE FOR METAL
 - MATTE FINISH FOR RUST



MANHOLE COVER
 SCALE: 3" = 1'-0"

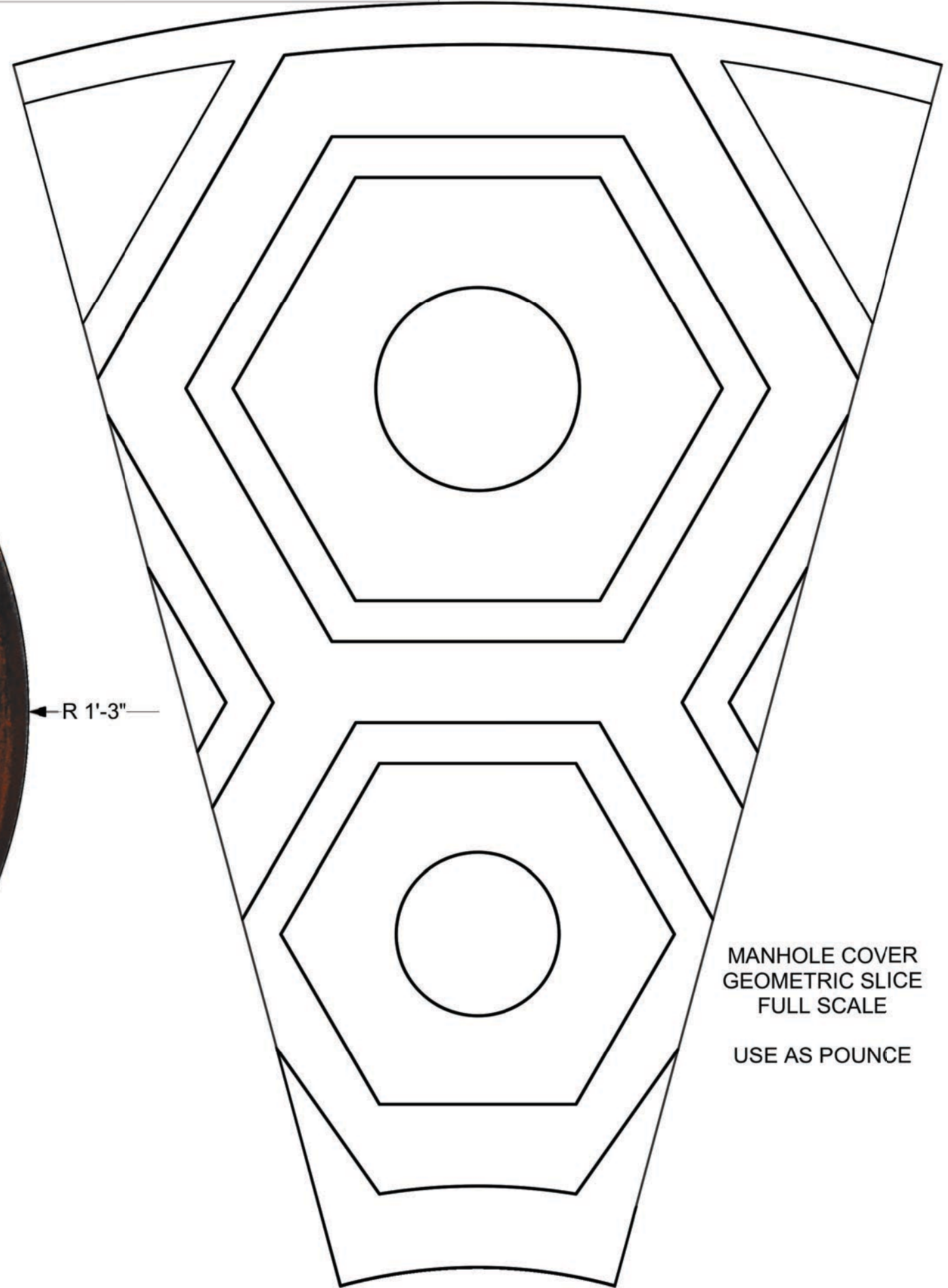

MANHOLE COVER
 GEOMETRIC SLICE
 FULL SCALE
 USE AS POUNCE

Disclaimer:
 Drawings are only meant only to illustrate ideas and are not to be used for construction. All designs must be evaluated and stamped by a certified technical director before construction. The designer does not assume any liability for structural integrity in the designs. The company selected to build the Designs will assume all liability to its structural integrity and related consumer, crew and performer safety.

Brandon M. Newton
 Scenic Designer Signature

Venue: Jeanine Larson Dobbins Conservatory
 Stage: Bedell Theatre
 Director: Kitt Lavoie
 Charge Artist: Brandon M. Newton

GUYS & DOLLS

Sheet Title: Paint Elevation - Floor: Manhole Cover
 Date: July 14, 2021
 Scale: Varies
 Designer: Brandon M. Newton
 Drawn By: Brandon M. Newton

Sheet Number:
ELE-1.2
 of 22

PAIN T ELEVATION - MARQUEE PORTAL

- SATIN FINISH
- RIGGING NEEDS TO BE BLACK IF IT CAN BE SEEN BY THE AUDIENCE

MARQUEE PORTAL TOP VIEW

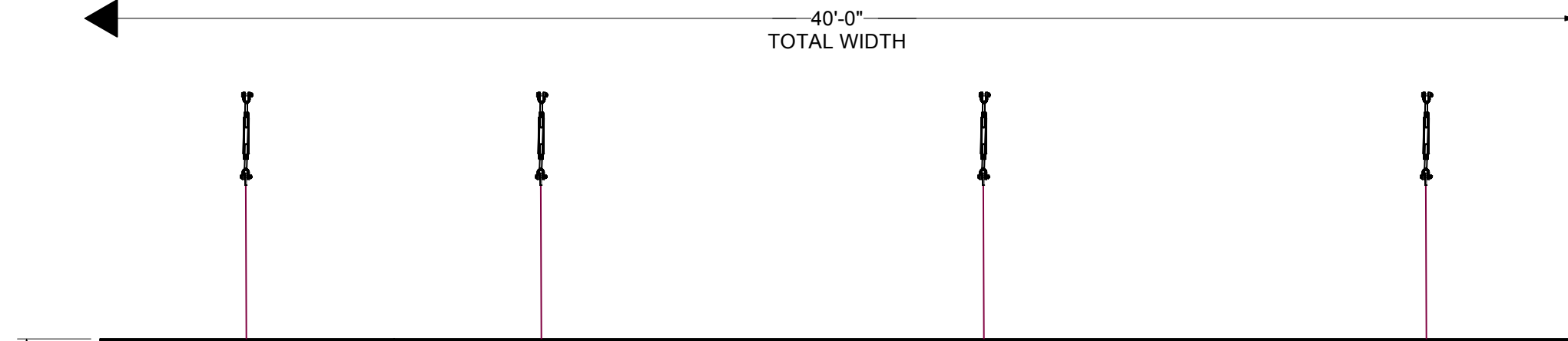

MARQUEE PORTAL FRONT VIEW



MARQUEE PORTAL SIDE/SECTION VIEW

Disclaimer:
 Drawings are only meant only to illustrate ideas and are not to be used for construction. All structural elements shown in the design must be evaluated and stamped by a certified technical director before construction. The designer does not assume any liability for structural integrity in the designs. The company selected to build the designs will assume all liability to its structural integrity and related consumer, crew and performer safety.

Brandon M. Newton
 Scenic Designer Signature

Venue:	Jeanine Larson Dobbins Conservatory
Stage:	Bedell Theatre
Director:	Kitt Lavoie
Charge Artist:	Brandon M. Newton

**G U Y S
&
D O L L S**

Sheet Title:	Paint Elevation - Marquee Portal
Date:	July 14, 2021
Scale:	1/2" = 1'-0"
Designer:	Brandon M. Newton
Drawn By:	Brandon M. Newton

PAINT ELEVATION - PORTAL 1 HEADER

- ALL HORIZONTAL SIGNS ARE APPROX. 4'x8'
- SIGNS (SCRIM) ARE MATTE FINISH
- FRAMES ARE SATIN FINISH
- BLACK SCRIM CAN STAY BLACK
- WRAP FACING TEXTURE ONTO ADJACENT SIDES

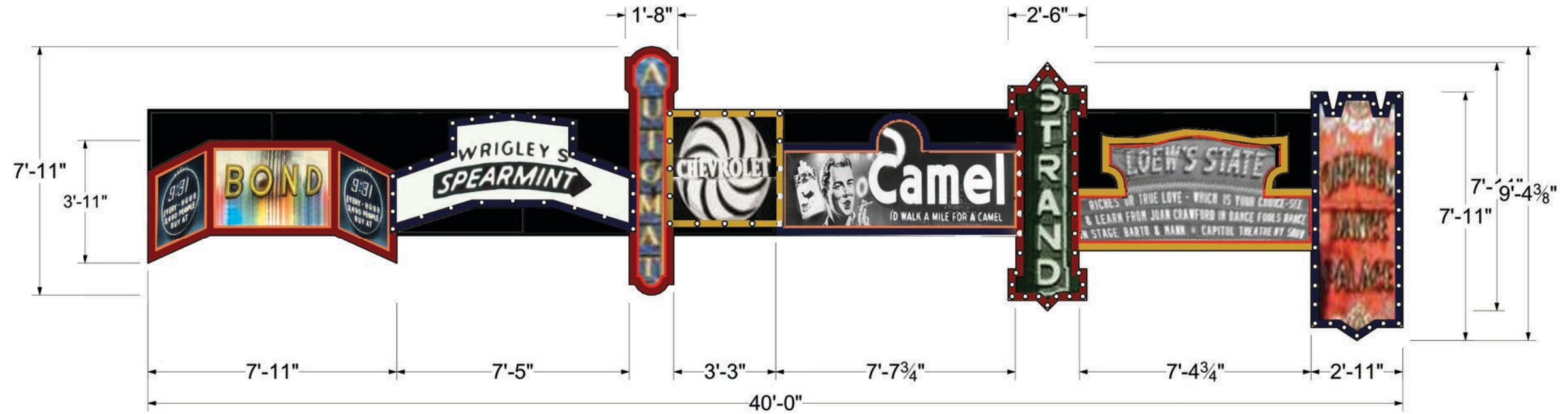

PORTAL 1 HEADER

Disclaimer:
 Drawings are only meant only to illustrate ideas and are not to be used for construction. All structural elements and details must be evaluated and stamped by a certified technical director before construction. The designer does not assume any liability for structural integrity in the designs. The company selected to build the designs will assume all liability to its structural integrity and related consumer, crew and performer safety.

Brandon M. Newton
 Scenic Designer Signature

Venue: Jeanine Larson Dobbins Conservatory
 Stage: Bedell Theatre
 Director: Kitt Lavoie
 Charge Artist: Brandon M. Newton

GUYS & DOLLS

Sheet Title: Paint Elevation - Portal 1 Header
 Date: July 14, 2021
 Scale: 1/4" = 1'-0"
 Designer: Brandon M. Newton
 Drawn By: Brandon M. Newton

Sheet Number: ELE-3.1
 of 22

PAINT ELEVATION - PORTAL 1 LEGS

- MATTE FINISH ON EVERYTHING EXCEPT SIGN FRAMES
- SATIN FINISH ON SIGN FRAMES
- WINDOWS GET MATTE SEALER WITH A TOUCH OF GRAY
- WRAP FACING TEXTURE ONTO ADJACENT SIDES

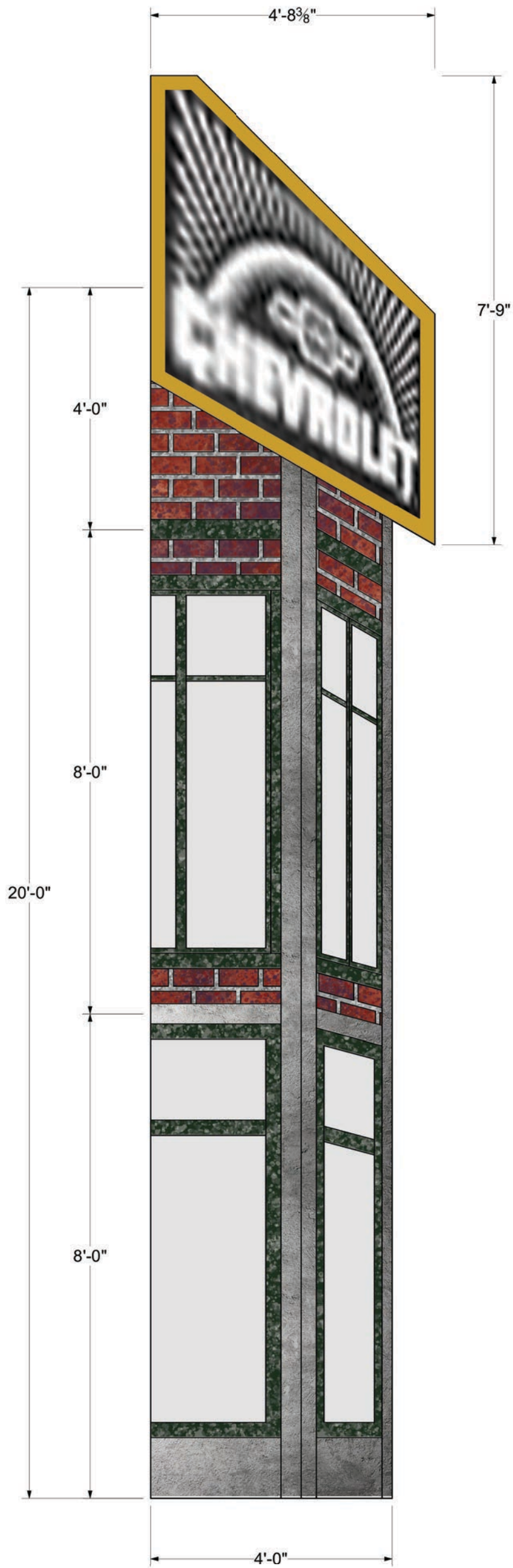

PORTAL 1 SR LEG

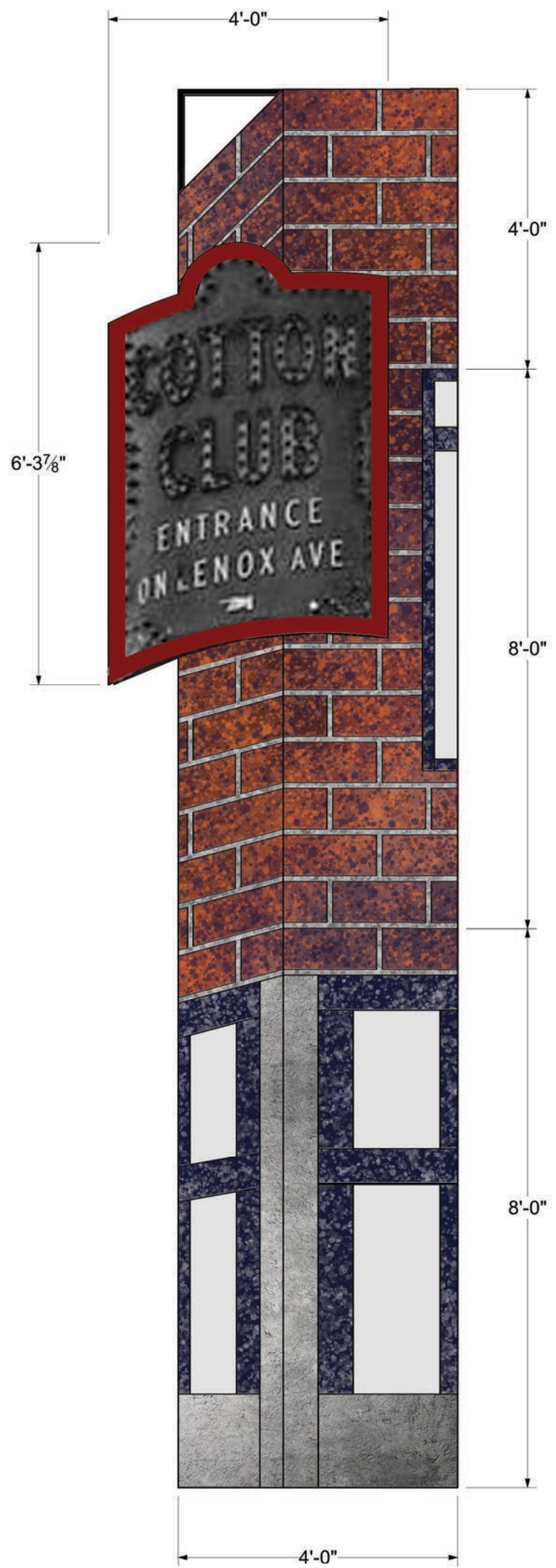

PORTAL 1 SL LEG

22 of ELE-3.2	Sheet Title: Paint Elevation - Portal 1 Legs	
	Date: July 14, 2021	Scale: 1/2" = 1'-0"
	Designer: Brandon M. Newton	Drawn By: Brandon M. Newton

**GUYS
&
DOLLS**

Venue: Jeanine Larson Dobbins Conservatory	
Stage: Bedell Theatre	
Director: Kitt Lavoie	Charge Artist: Brandon M. Newton

Disclaimer:
Drawings are only meant to illustrate ideas and aesthetics for the project. Any and all structural elements shown in the design must be evaluated and stamped by a certified technical director before construction. The designer does not assume any liability for structural integrity in the designs. The company selected to build the Designs will assume all liability to its structural integrity and related consumer, crew and performer safety.

Brandon M. Newton
Scenic Designer Signature

PAINT ELEVATION - PORTAL 1 HEADER

- ALL HORIZONTAL SIGNS ARE APPROX. 4'x8'
- SIGNS (SCRIM) ARE MATTE FINISH
- FRAMES ARE SATIN FINISH
- BLACK SCRIM CAN STAY BLACK
- WRAP FACING TEXTURE ONTO ADJACENT SIDES

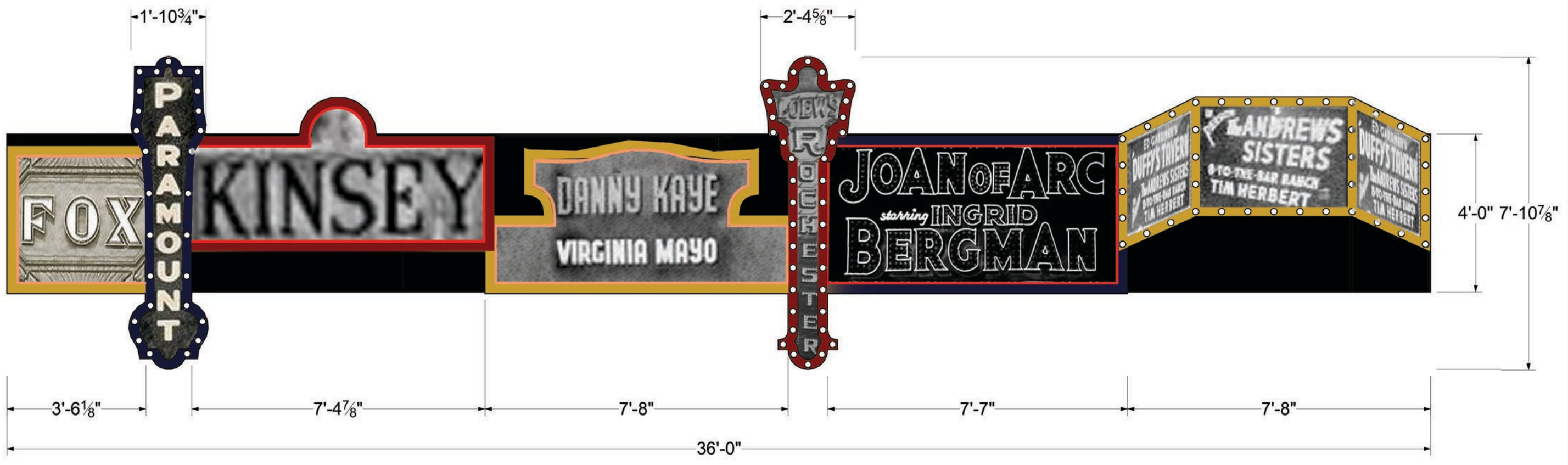

PORTAL 2 HEADER

Disclaimer:
 Drawings are only meant only to illustrate ideas and are not to be used for construction. All structural elements must be evaluated and stamped by a certified technical director before construction. The designer does not assume any liability for structural integrity in the designs. The company selected to build the designs will assume all liability to its structural integrity and related consumer, crew and performer safety.

Brandon M. Newton
 Scenic Designer Signature

Venue:	Jeanine Larson Dobbins Conservatory
Stage:	Bedell Theatre
Director:	Kitt Lavoie
Charge Artist:	Brandon M. Newton

GUYS & DOLLS

Sheet Title:	Paint Elevation - Portal 2 Header
Date:	July 14, 2021
Scale:	3/8" = 1'-0"
Designer:	Brandon M. Newton
Drawn By:	Brandon M. Newton

PAIN T ELEVATION - PORTAL 2 LEGS

- MATTE FINISH ON EVERYTHING EXCEPT SIGN FRAMES
- SATIN FINISH ON SIGN FRAMES
- WINDOWS GET MATTE SEALER WITH A TOUCH OF GRAY
- WRAP FACING TEXTURE ONTO ADJACENT SIDES

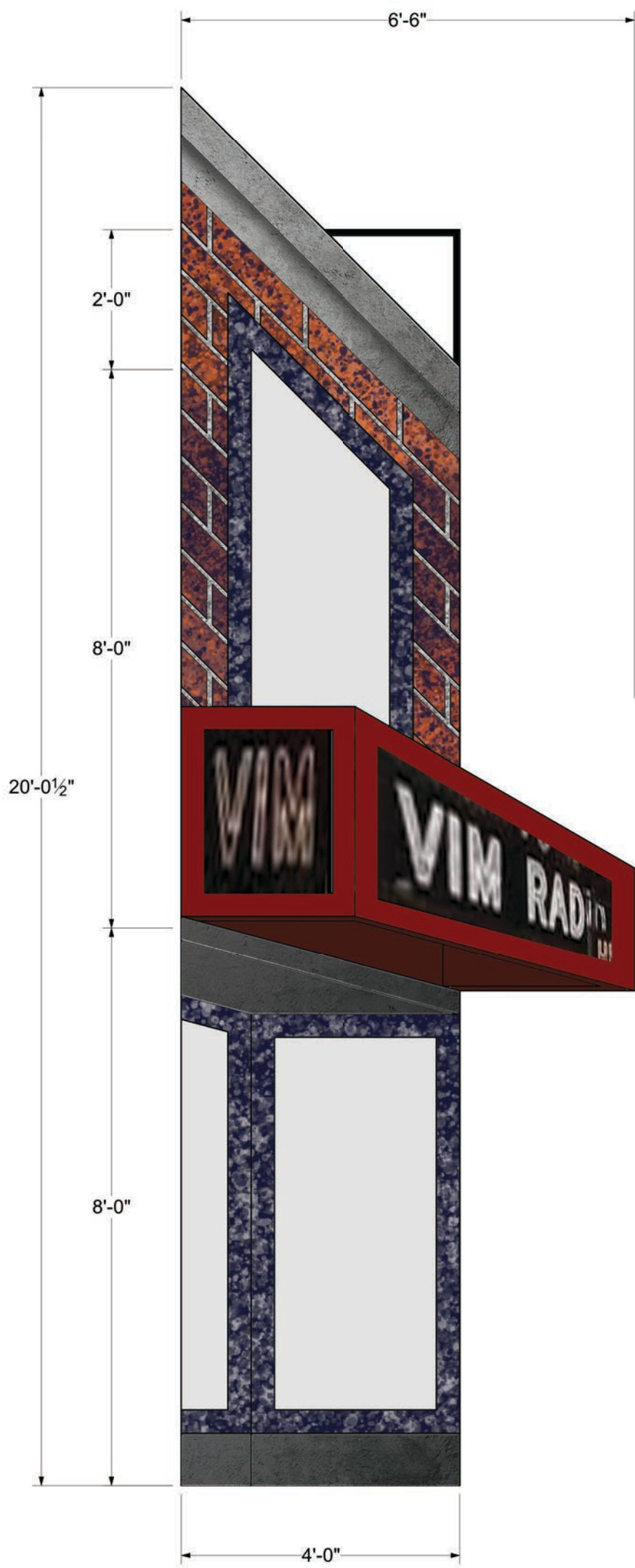

PORTAL 2 SR LEG

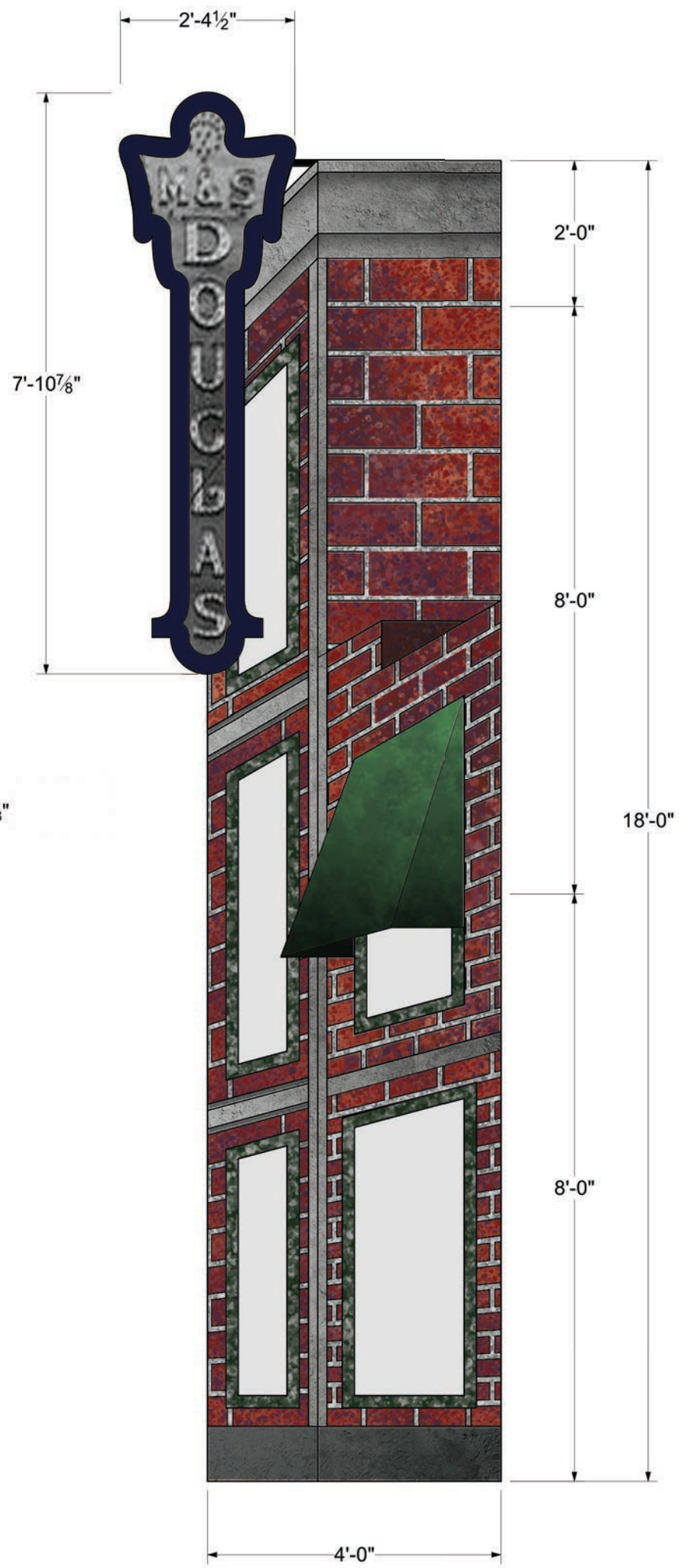

PORTAL 2 SL LEG

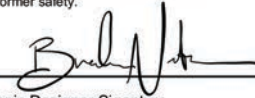
22 of ELE-4.2	Sheet Title: Paint Elevation - Portal 2 Legs		GUYS & DOLLS	Venue: Jeanine Larson Dobbins Conservatory		Disclaimer: Drawings are only meant only to illustrate ideas and aesthetics for the project. Any and all structural elements shown in the design must be evaluated and stamped by a certified technical director before construction. The designer does not assume any liability for structural integrity in the designs. The company selected to build the Designs will assume all liability to its structural integrity and related consumer, crew and performer safety.  Scenic Designer Signature
	Date: July 14, 2021	Scale: 1/2" = 1'-0"		Stage: Bedell Theatre		
	Designer: Brandon M. Newton	Drawn By: Brandon M. Newton		Director: Kitt Lavoie	Charge Artist: Brandon M. Newton	

PAIN T ELEVATION - PORTAL 1 HEADER

- ALL HORIZONTAL SIGNS ARE APPROX. 4'x8'
- SIGNS (SCRIM) ARE MATTE FINISH
- FRAMES ARE SATIN FINISH
- BLACK SCRIM CAN STAY BLACK
- WRAP FACING TEXTURE ONTO ADJACENT SIDES

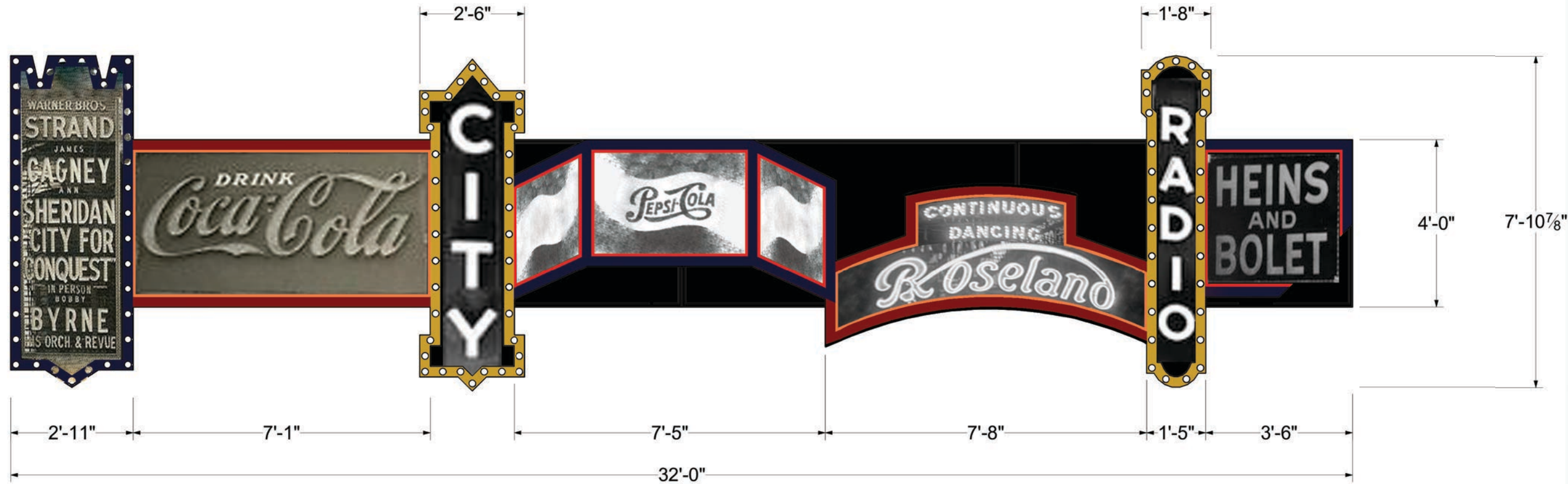

PORTAL 3 HEADER

Disclaimer:
 Drawings are only meant only to illustrate ideas and are not to be used for construction. All structural elements must be evaluated and stamped by a certified technical director before construction. The designer does not assume any liability for structural integrity in the designs. The company selected to build the designs will assume all liability to its structural integrity and related consumer, crew and performer safety.

Brandon M. Newton
 Scenic Designer Signature

Venue:	Jeanine Larson Dobbins Conservatory
Stage:	Bedell Theatre
Director:	Kitt Lavoie
Charge Artist:	Brandon M. Newton

GUYS & DOLLS

Sheet Title:	Paint Elevation - Portal 3 Header
Date:	July 14, 2021
Scale:	3/8" = 1'-0"
Designer:	Brandon M. Newton
Drawn By:	Brandon M. Newton

Sheet Number:
ELE-5.1
 of 22

PAINT ELEVATION - PORTAL 3 LEGS

- MATTE FINISH ON EVERYTHING EXCEPT SIGN FRAMES
- SATIN FINISH ON SIGN FRAMES
- WINDOWS GET MATTE SEALER WITH A TOUCH OF GRAY
- WRAP FACING TEXTURE ONTO ADJACENT SIDES

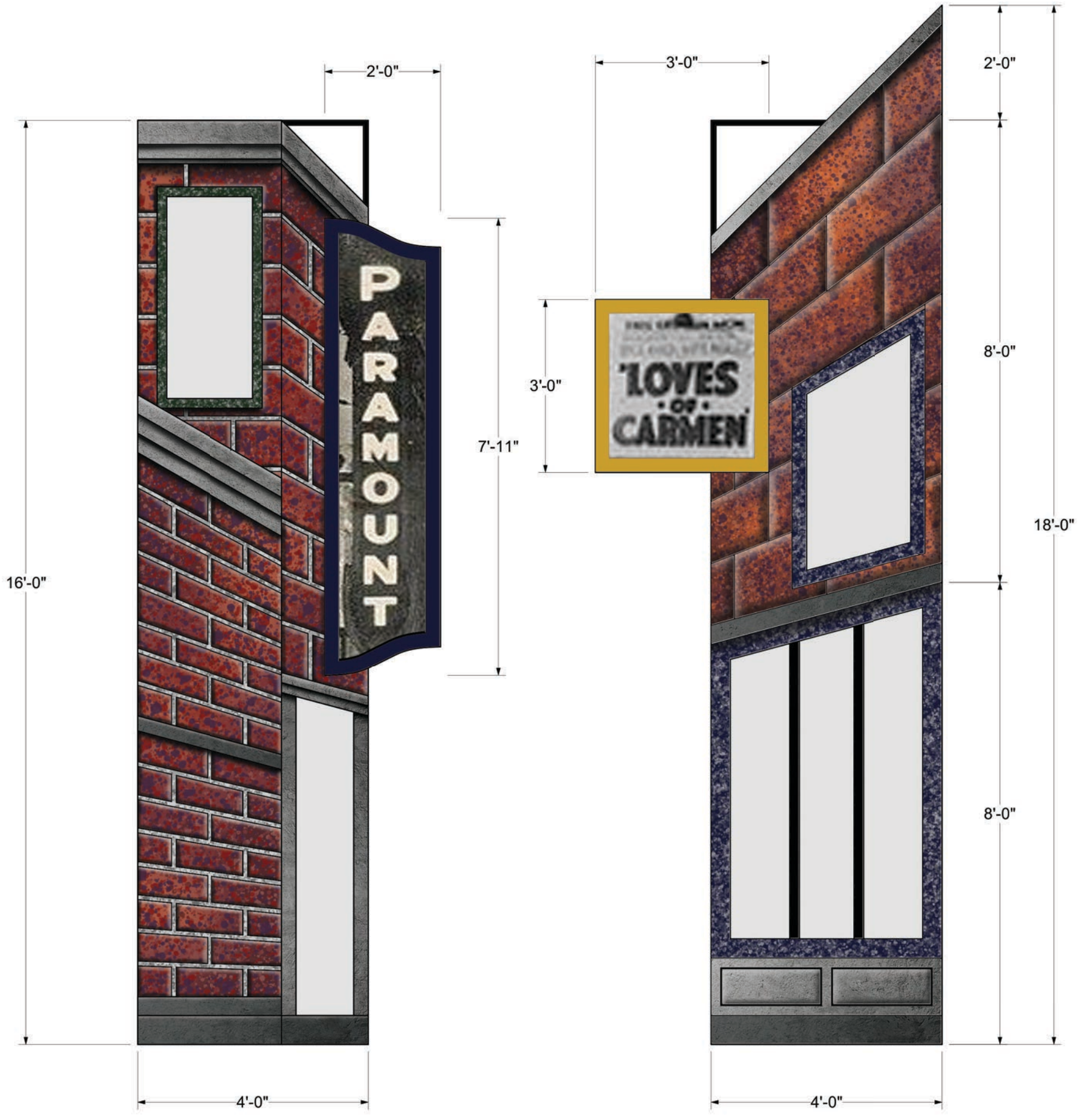

PORTAL 3 SR LEG

PORTAL 3 SL LEG

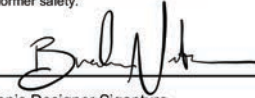
22 of ELE-5.2	Sheet Title: Paint Elevation - Portal 3 Legs		GUYS & DOLLS	Venue: Jeanine Larson Dobbins Conservatory		Disclaimer: Drawings are only meant to illustrate ideas and aesthetics for the project. Any and all structural elements shown in the design must be evaluated and stamped by a certified technical director before construction. The designer does not assume any liability for structural integrity in the designs. The company selected to build the Designs will assume all liability to its structural integrity and related consumer, crew and performer safety.  Scenic Designer Signature
	Date: July 14, 2021	Scale: 1/2" = 1'-0"		Stage: Bedell Theatre		
	Designer: Brandon M. Newton	Drawn By: Brandon M. Newton		Director: Kitt Lavoie	Charge Artist: Brandon M. Newton	

PAIN T ELEVATION - SKYLINE

- MATTE FINISH ON FACING
- WINDOWS GET MATTE SEALER WITH A TOUCH OF GRAY
- TRY TO HIDE SEAMS

SKYLINE TOP VIEW

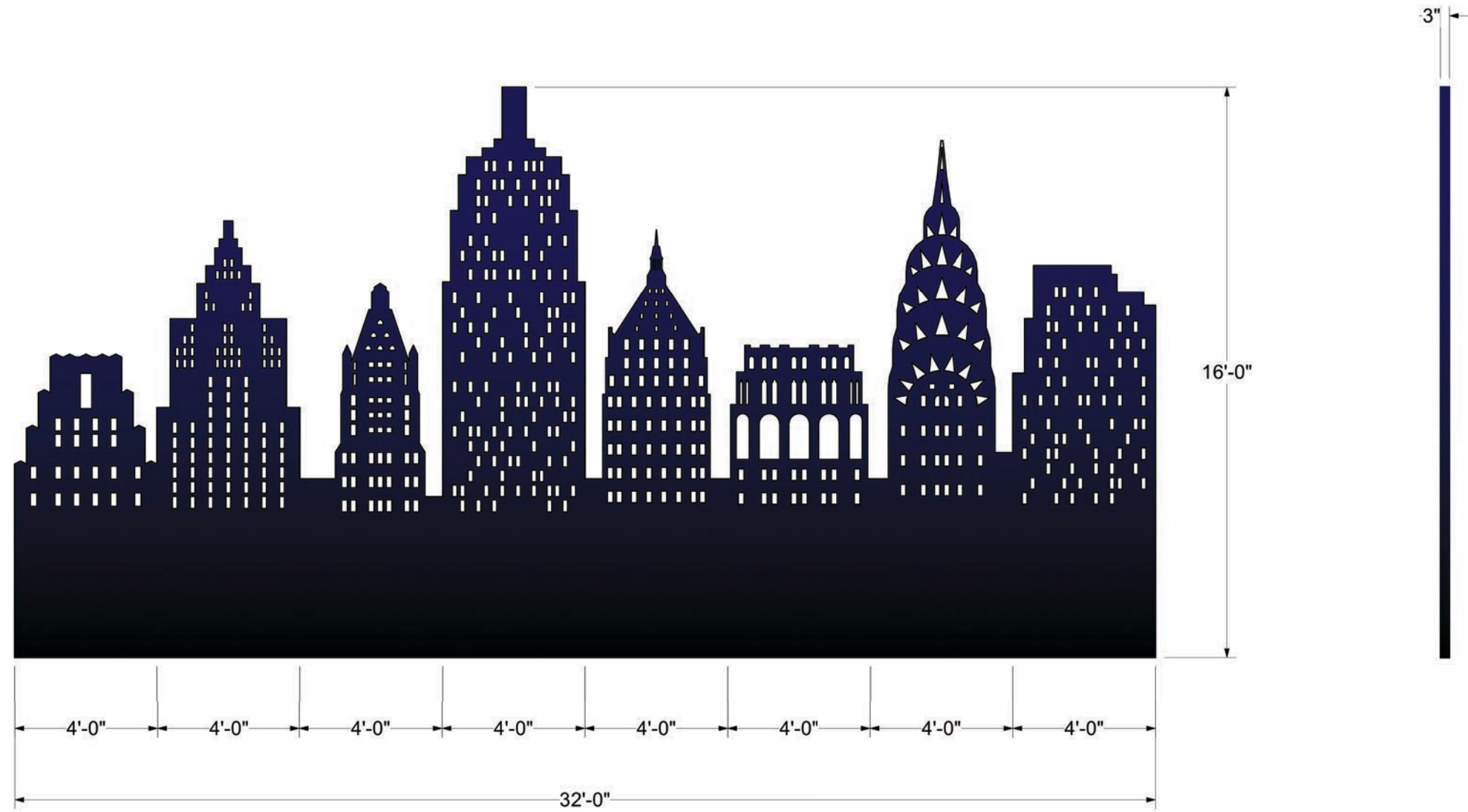

SKYLINE FRONT VIEW

SKYLINE SIDE VIEW

Disclaimer:
 Drawings are only meant only to illustrate ideas and are not to be used for construction. All designs must be evaluated and stamped by a certified technical director before construction. The designer does not assume any liability for structural integrity in the designs. The company selected to build the designs will assume all liability to its structural integrity and related consumer, crew and performer safety.

Brandon M. Newton
 Scenic Designer Signature

Venue: Jeanine Larson Dobbins Conservatory
 Stage: Bedell Theatre
 Director: Kitt Lavoie
 Charge Artist: Brandon M. Newton

GUYS & DOLLS

Sheet Title: Paint Elevation - Skyline
 Date: July 14, 2021
 Designer: Brandon M. Newton
 Scale: 1/4" = 1'-0"
 Drawn By: Brandon M. Newton

Sheet Number: **ELE-6**
 of 22

PAINT ELEVATION - DS BUILDING

- FLAT FACING HAS MATTE FINISH
- SIGNS (SCRIM) ARE MATTE FINISH
- FRAMES ARE SATIN FINISH
- WINDOWS HAVE MATTE FINISH WITH A TOUCH OF GRAY
- WRAP FACING TEXTURE ONTO ADJACENT SIDES

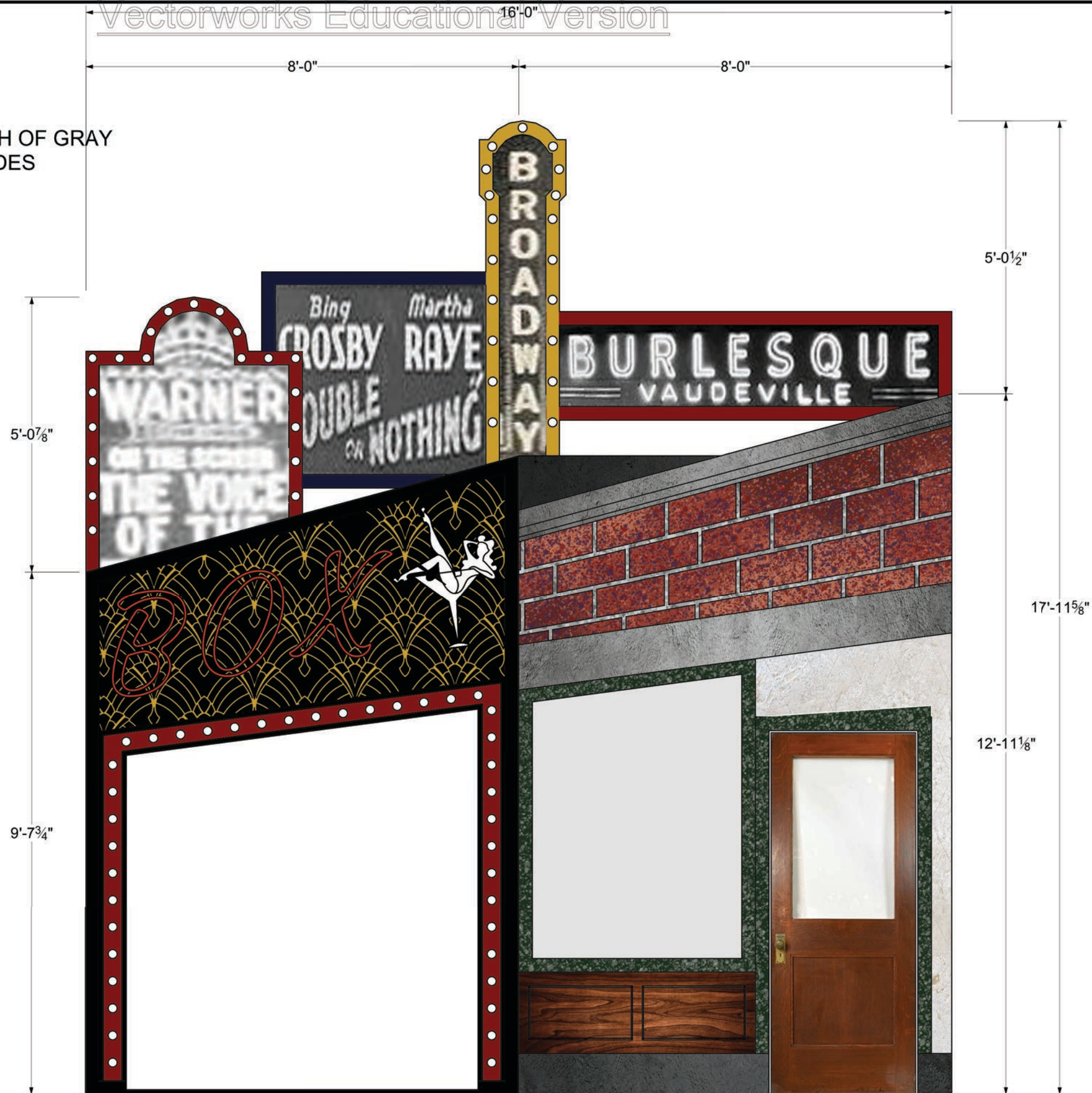

DS BUILDING FRONT VIEW

Disclaimer:
 Drawings are only meant only to illustrate ideas and are not to be used for construction. All designs must be evaluated and stamped by a certified technical director before construction. The designer does not assume any liability for structural integrity in the designs. The company selected to build the designs will assume all liability to its structural integrity and related consumer, crew and performer safety.

Brandon M. Newton
 Scenic Designer Signature

Venue:	Jeanine Larson Dobbins Conservatory
Stage:	Bedell Theatre
Director:	Kitt Lavoie
Charge Artist:	Brandon M. Newton

GUYS & DOLLS

Sheet Title:	Paint Elevation - DS Buildings: Base
Date:	July 14, 2021
Designer:	Brandon M. Newton
Scale:	1/2" = 1'-0"
Drawn By:	Brandon M. Newton

Sheet Number:
ELE-7
 of 22

PAINT ELEVATION - DS BUILDING: SWING WALL

- FLAT FACING HAS MATTE FINISH
- NEON IS HIGH GLOSS FINISH
- WINDOWS HAVE MATTE FINISH WITH A TOUCH OF GRAY
- WRAP FACING TEXTURE ONTO ADJACENT SIDES

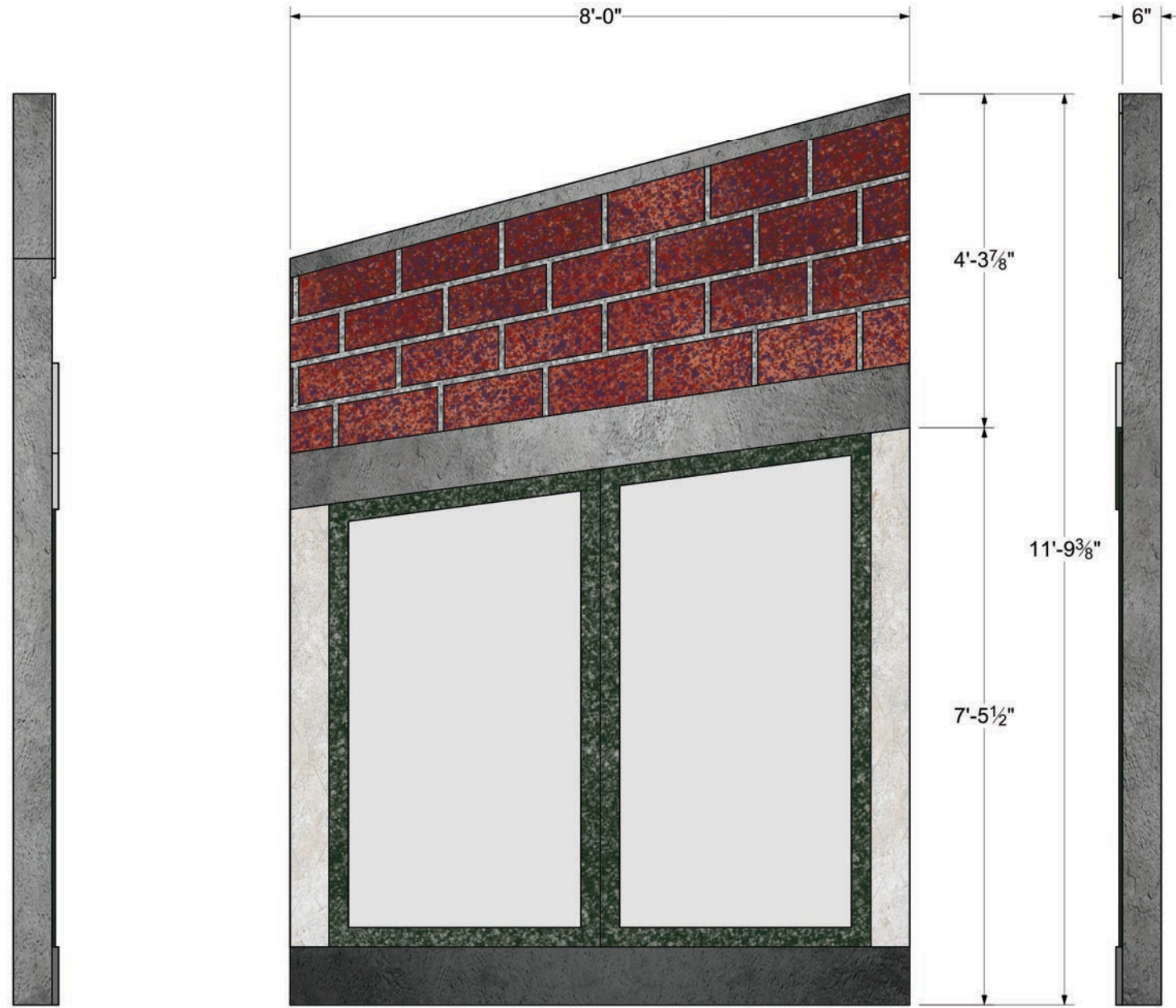

DS BUILDING SWING WALL LEFT VIEW

DS BUILDING SWING WALL FRONT VIEW

DS BUILDING SWING WALL RIGHT VIEW

DS BUILDING SWING WALL BACK VIEW

DS BUILDING SWING WALL TOP VIEW



Disclaimer:
 Drawings are only meant only to illustrate ideas and are not to be used for construction purposes. The designer does not assume any liability for structural integrity in the designs. The company selected to build the designs will assume all liability to its structural integrity and related consumer, crew and performer safety.

Scenic Designer Signature
 Brandon M. Newton

Venue: Jeanine Larson Dobbins Conservatory
 Stage: Bedell Theatre
 Director: Kitt Lavoie
 Charge Artist: Brandon M. Newton

GUYS & DOLLS

Sheet Title: Paint Elevation - DS Buildings: Swing Wall
 Date: July 14, 2021
 Scale: 1/2" = 1'-0"
 Designer: Brandon M. Newton
 Drawn By: Brandon M. Newton

PAINT ELEVATION - US BUILDING

- FLAT FACING HAS MATTE FINISH
- SIGNS (SCRIM) ARE MATTE FINISH
- FRAMES ARE SATIN FINISH
- WINDOWS HAVE MATTE FINISH WITH A TOUCH OF GRAY
- WRAP FACING TEXTURE ONTO ADJACENT SIDES

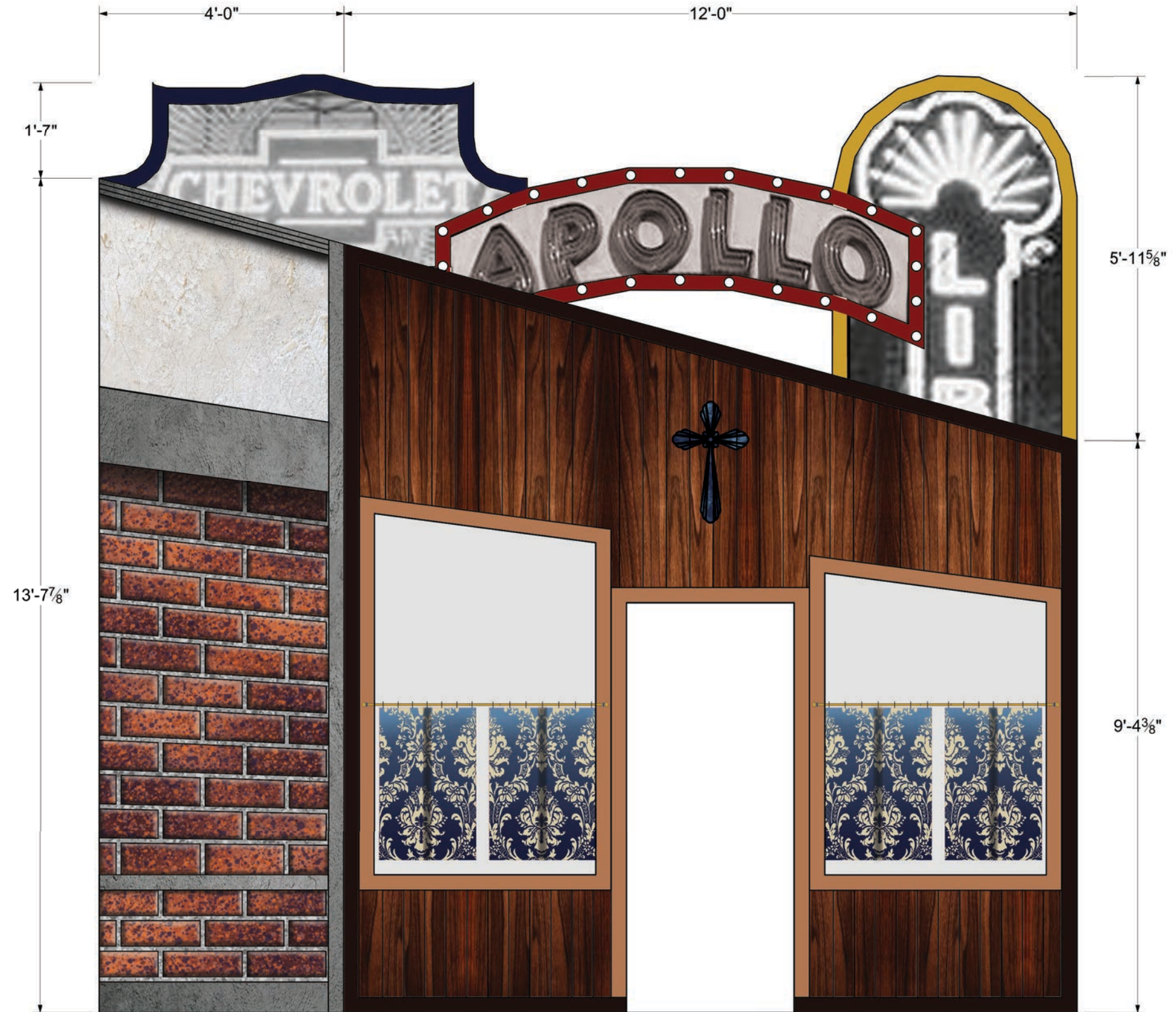

US BUILDING FRONT VIEW

Disclaimer:
 Drawings are only meant only to illustrate ideas and are not to be used for construction. All structural elements and details must be evaluated and stamped by a certified technical director before construction. The designer does not assume any liability for structural integrity in the designs. The company selected to build the designs will assume all liability to its structural integrity and related consumer, crew and performer safety.

Brandon M. Newton
 Scenic Designer Signature

Venue:	Jeanine Larson Dobbins Conservatory
Stage:	Bedell Theatre
Director:	Kitt Lavoie
Charge Artist:	Brandon M. Newton

GUYS & DOLLS

Sheet Title:	Paint Elevation - US Buildings: Base
Date:	July 14, 2021
Scale:	1/2" = 1'-0"
Designer:	Brandon M. Newton
Drawn By:	Brandon M. Newton

Sheet Number:
ELE-9
 of 22

PAINT ELEVATION - US BUILDING: SWING WALL

- FLAT FACING HAS MATTE FINISH
- NEON IS HIGH GLOSS FINISH
- WINDOWS HAVE MATTE FINISH WITH A TOUCH OF GRAY
- WRAP FACING TEXTURE ONTO ADJACENT SIDES

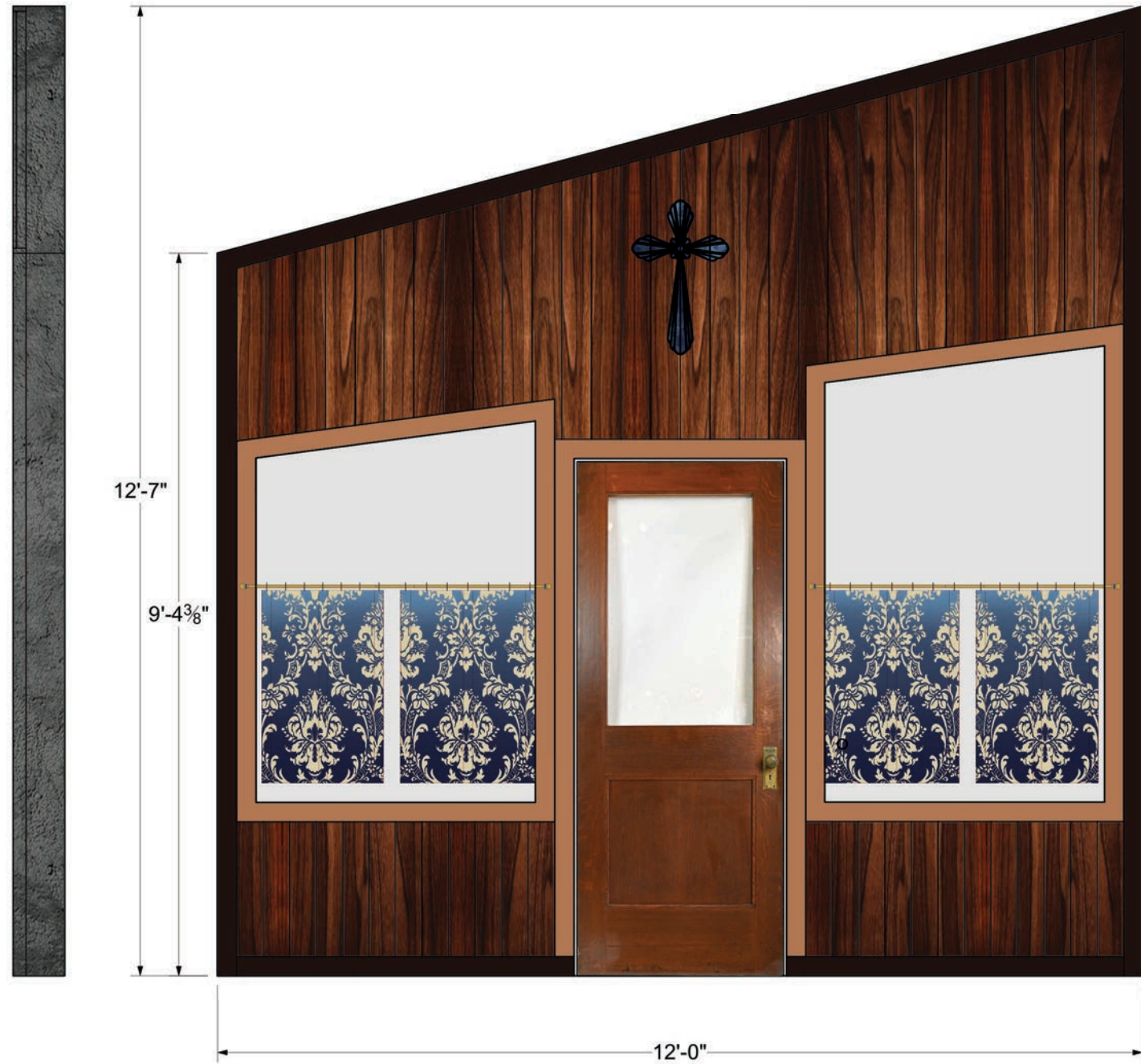

US BUILDING SWING WALL RIGHT VIEW

US BUILDING SWING WALL BACK VIEW



US BUILDING SWING WALL LEFT VIEW



US BUILDING SWING WALL TOP VIEW

US BUILDING SWING WALL FRONT VIEW

Disclaimer:
 Drawings are only meant only to illustrate ideas and are not to be used for construction. All designs must be evaluated and stamped by a certified technical director before construction. The designer does not assume any liability for structural integrity in the designs. The company selected to build the designs will assume all liability to its structural integrity and related consumer, crew and performer safety.

Brandon M. Newton
 Scenic Designer Signature

Venue: Jeanine Larson Dobbins Conservatory
 Stage: Bedell Theatre
 Director: Kitt Lavoie
 Charge Artist: Brandon M. Newton

GUYS & DOLLS

Sheet Title: Paint Elevation - US Buildings: Swing Wall
 Date: July 14, 2021
 Scale: 1/2" = 1'-0"
 Designer: Brandon M. Newton
 Drawn By: Brandon M. Newton

PAIN T ELEVATION - SEWER TUNNEL
 - MATTE FINISH
 - WRAP FACING TEXTURE ONTO ADJACENT SIDES



SEWER TUNNEL FRONT VIEW

Disclaimer:
 Drawings are only meant only to illustrate ideas and are not to be used for construction. All designs must be evaluated and stamped by a certified technical director before construction. The designer does not assume any liability for structural integrity in the designs. The company selected to build the Designs will assume all liability to its structural integrity and related consumer, crew and performer safety.

Brandon M. Newton
 Scenic Designer Signature

Venue: **Jeanine Larson Dobbins Conservatory**
 Stage: **Bedell Theatre**
 Director: **Kitt Lavoie**
 Charge Artist: **Brandon M. Newton**

GUYS & DOLLS

Sheet Title: **Paint Elevation - Sewer Tunnel**
 Date: **July 14, 2021**
 Designer: **Brandon M. Newton**
 Scale: **1/2" = 1'-0"**
 Drawn By: **Brandon M. Newton**

Sheet Number:
ELE-11
 of 22

PAINT ELEVATION - SEWER GRATES

- START WITH METALLIC FINISH
- RUST/AGE HAS MATTE FINISH
- WRAP FACING TEXTURE ONTO ADJACENT SIDES

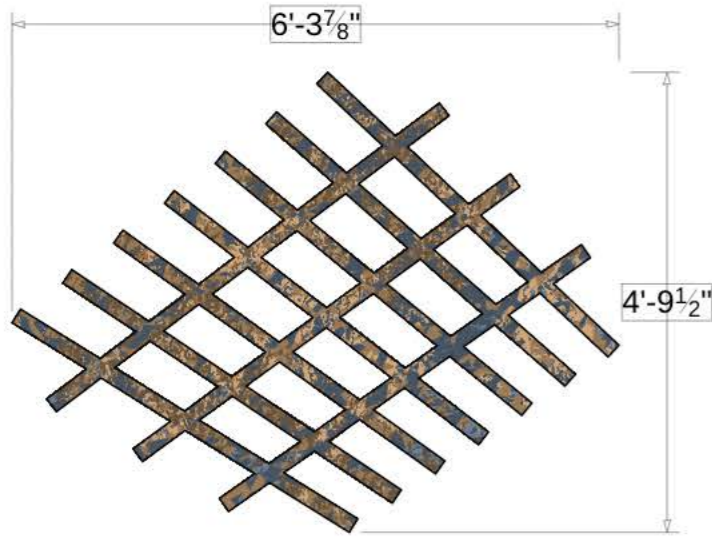

USR GRATE

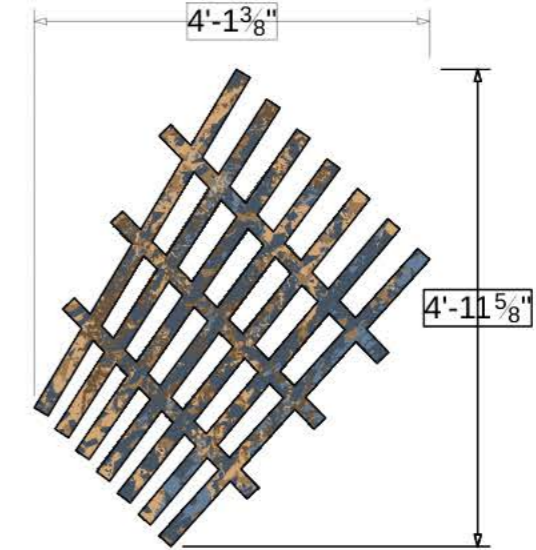

USL GRATE

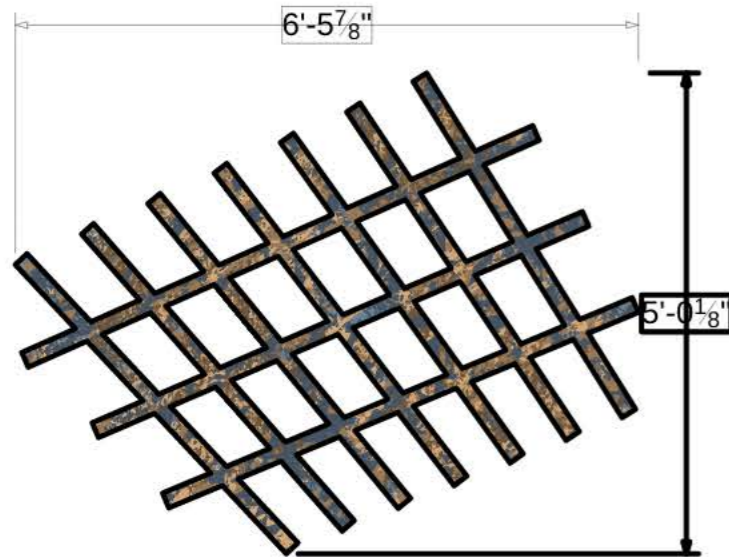

DSR GRATE

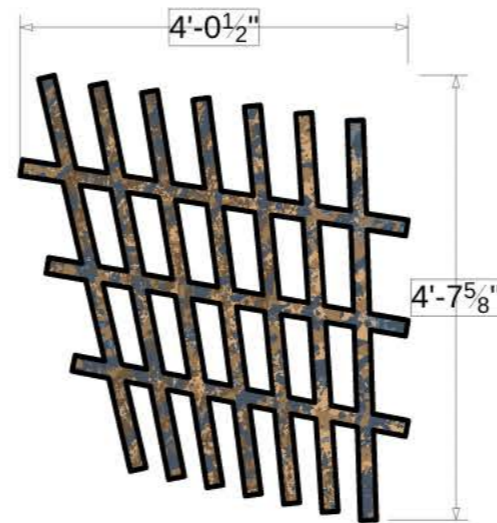

DSC GRATE

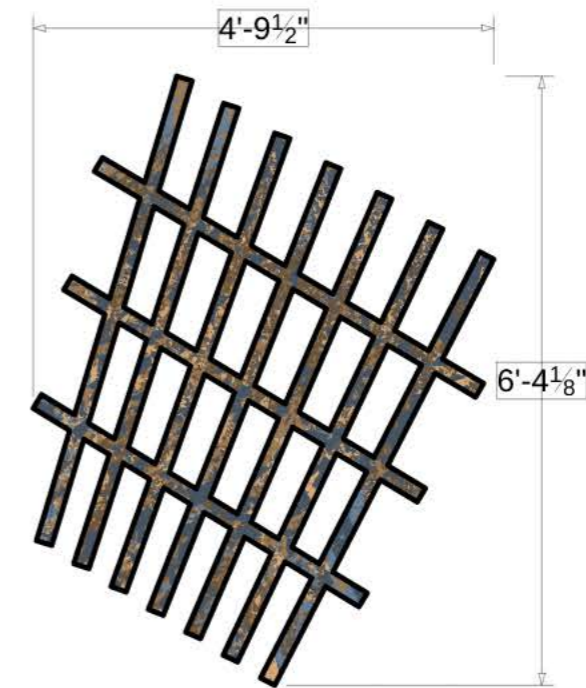

DSL GRATE

Disclaimer:
 Drawings are only meant only to illustrate ideas and are not to be used for construction. All designs and structural elements of the design must be evaluated and stamped by a certified technical director before construction. The designer does not assume any liability for structural integrity in the designs. The company selected to build the designs will assume all liability to its structural integrity and related consumer, crew and performer safety.

Brandon M. Newton
 Scenic Designer Signature

Venue: Jeanine Larson Dobbins Conservatory

Stage: Bedell Theatre

Director: Kitt Lavoie
 Charge Artist: Brandon M. Newton

GUYS & DOLLS

Sheet Title: Paint Elevation - Sewer Grates

Date: July 14, 2021
 Scale: 1/2" = 1'-0"

Designer: Brandon M. Newton
 Drawn By: Brandon M. Newton

Sheet Number:

ELE-12

of 22

PAINT ELEVATION - DS HAVANA

- MATTE FINISH
- WRAP FACING TEXTURE ONTO ADJACENT SIDES
- LEAVES WILL BE DONE BY SCENERY OR PROPS



DS HAVANA TOP VIEW



DS HAVANA LEFT VIEW

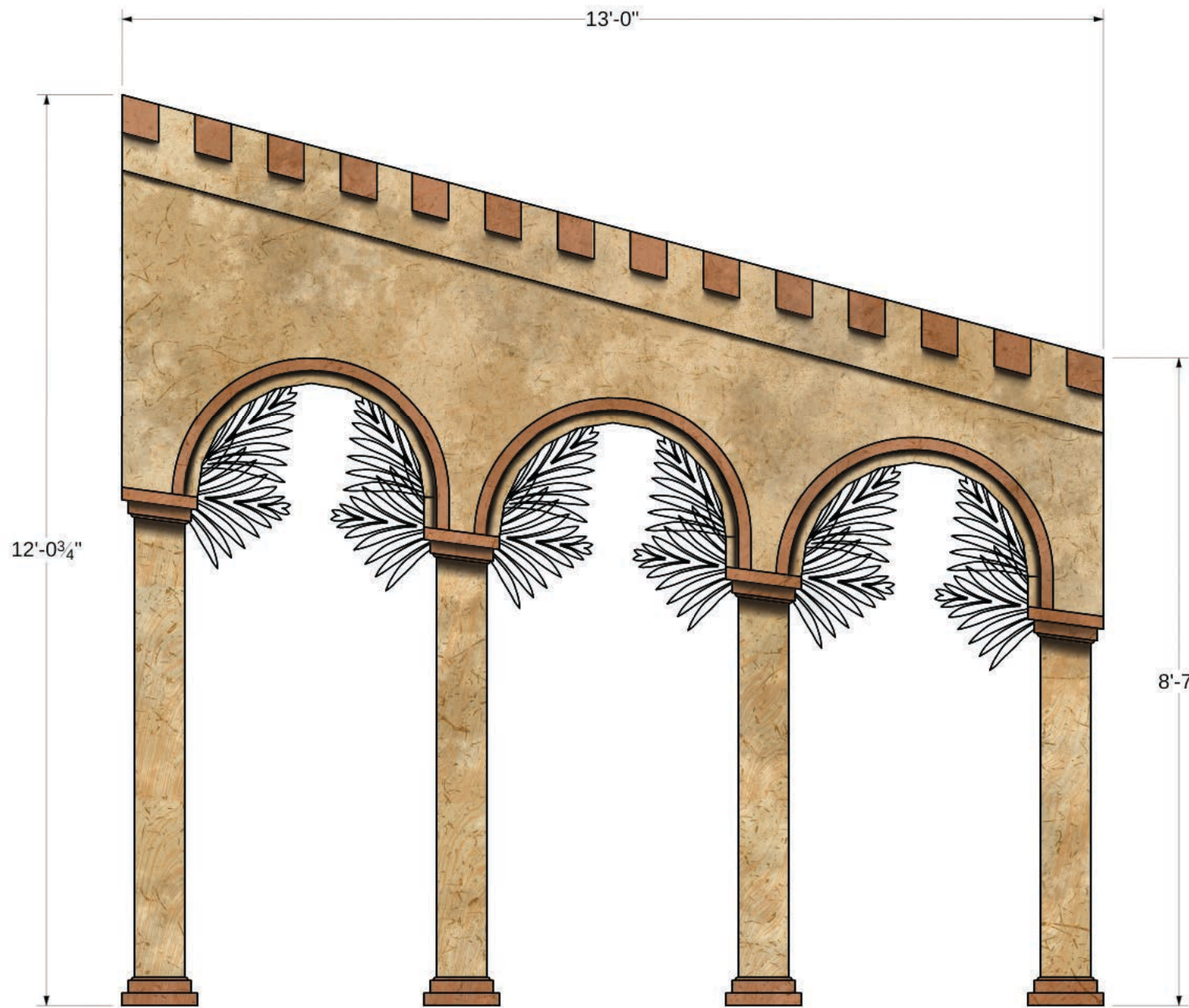

DS HAVANA FRONT VIEW



DS HAVANA RIGHT VIEW

Disclaimer:
 Drawings are only meant only to illustrate ideas and are not to be used for construction. All designs must be evaluated and stamped by a certified technical director before construction. The designer does not assume any liability for structural integrity in the designs. The company selected to build the designs will assume all liability to its structural integrity and related consumer, crew and performer safety.

Brandon M. Newton
 Scenic Designer Signature

Venue:	Jeanine Larson Dobbins Conservatory
Stage:	Bedell Theatre
Director:	Kitt Lavoie
Charge Artist:	Brandon M. Newton

GUYS & DOLLS

Sheet Title:	Paint Elevation - DS Havana
Date:	July 14, 2021
Designer:	Brandon M. Newton
Scale:	1/2" = 1'-0"
Drawn By:	Brandon M. Newton

PAINT ELEVATION - DS HAVANA

- MATTE FINISH
- WRAP FACING TEXTURE ONTO ADJACENT SIDES
- LEAVES WILL BE DONE BY SCENERY OR PROPS



US HAVANA TOP VIEW

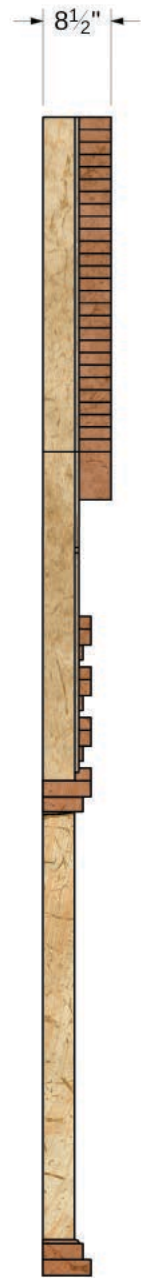

US HAVANA LEFT VIEW

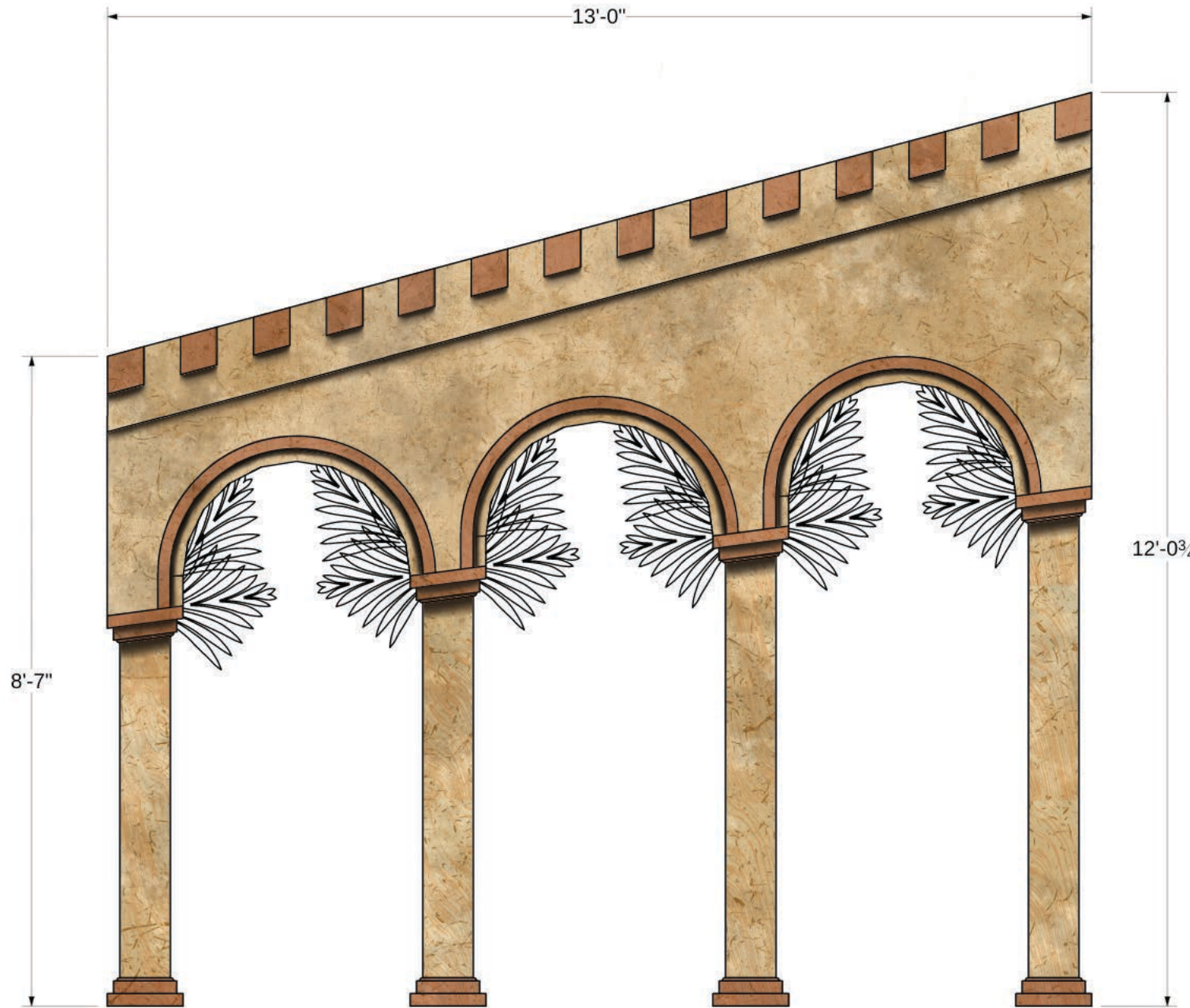

US HAVANA FRONT VIEW



US HAVANA RIGHT VIEW

Disclaimer:
 Drawings are only meant only to illustrate ideas and are not intended for construction. They must be evaluated and stamped by a certified technical director before construction. The designer does not assume any liability for structural integrity in the designs. The company selected to build the designs will assume all liability to its structural integrity and related consumer, crew and performer safety.

Brandon M. Newton
 Scenic Designer Signature

Venue:	Jeanine Larson Dobbins Conservatory
Stage:	Bedell Theatre
Director:	Kitt Lavoie
Charge Artist:	Brandon M. Newton

GUYS & DOLLS

Sheet Title:	Paint Elevation - US Havana
Date:	July 14, 2021
Scale:	1/2" = 1'-0"
Designer:	Brandon M. Newton
Drawn By:	Brandon M. Newton

PAINT ELEVATION - HOT BOX PLATFORM
 - SATIN FINISH
 - WRAP FACING TEXTURE ONTO ADJACENT SIDES



HOT BOX PLATFORM TOP VIEW

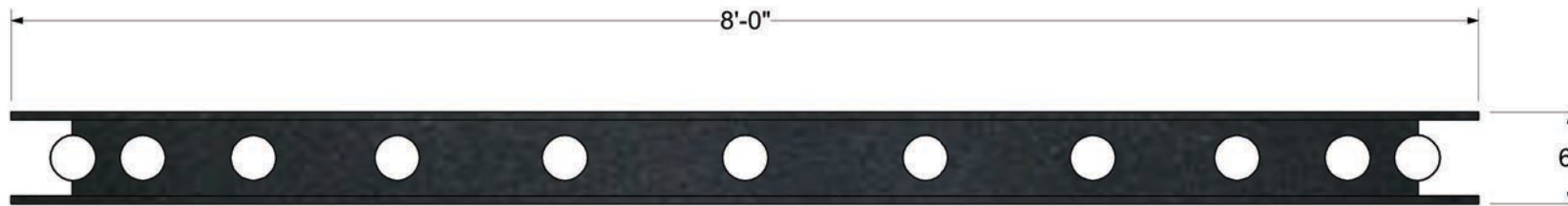

HOT BOX PLATFORM FRONT VIEW



HOT BOX PLATFORM SIDE VIEW

Disclaimer:
 Drawings are only meant only to illustrate ideas and are not to be used for construction. All structural elements and details must be evaluated and stamped by a certified technical director before construction. The designer does not assume any liability for structural integrity in the designs. The company selected to build the designs will assume all liability to its structural integrity and related consumer, crew and performer safety.

Brandon M. Newton
 Scenic Designer Signature

Venue: **Jeanine Larson Dobbins Conservatory**
 Stage: **Bedell Theatre**
 Director: **Kitt Lavoie**
 Charge Artist: **Brandon M. Newton**

GUYS & DOLLS

Sheet Title: **Paint Elevation - Hot Box Platform**
 Date: **July 14, 2021**
 Designer: **Brandon M. Newton**
 Scale: **1" = 1'-0"**
 Drawn By: **Brandon M. Newton**

Sheet Number: **ELE-15**
 of 22

PAINT ELEVATION - NEWSPAPER STAND

- MATTE FINISH
- WRAP FACING TEXTURE ONTO ADJACENT SIDES

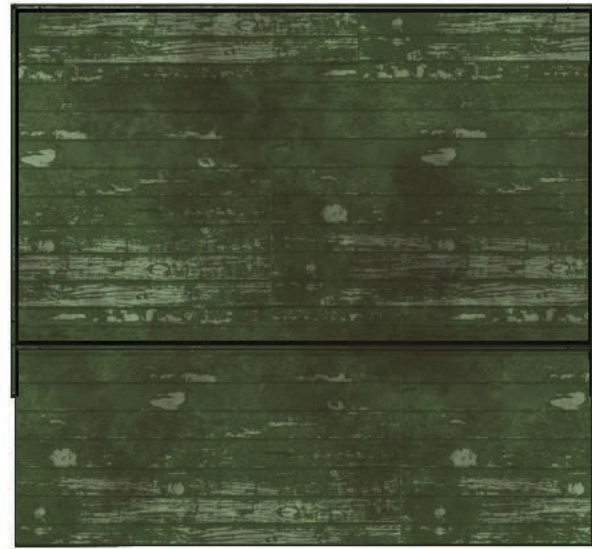

NEWSPAPER STAND TOP VIEW

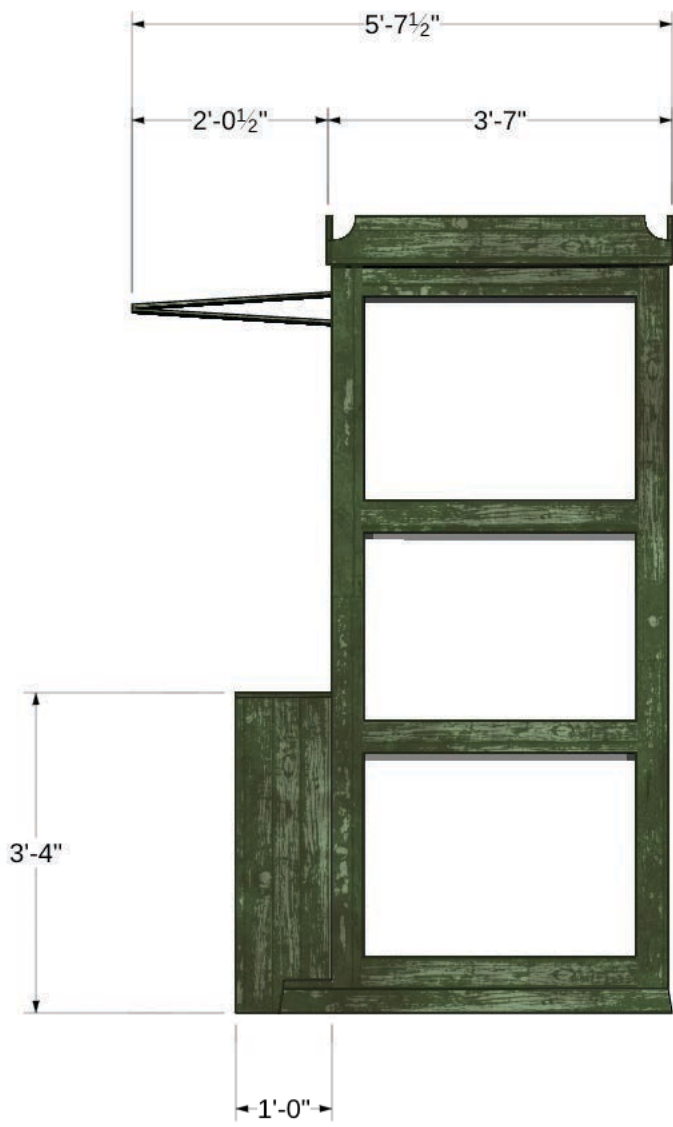

NEWSPAPER STAND SIDE VIEW
(MIRROR OTHER SIDE)



NEWSPAPER STAND FRONT VIEW
(UNIT IS SYMMETRYICAL)

22 of ELE-16	Sheet Title: Paint Elevation - Newspaper Stand	
	Date: July 14, 2021	Scale: 1/2" = 1'-0"
	Designer: Brandon M. Newton	Drawn By: Brandon M. Newton

**GUYS
&
DOLLS**

Venue: Jeanine Larson Dobbins Conservatory	
Stage: Bedell Theatre	
Director: Kitt Lavoie	Charge Artist: Brandon M. Newton

Disclaimer:
Drawings are only meant to illustrate ideas and aesthetics for the project. Any and all structural elements shown in the design must be evaluated and stamped by a certified technical director before construction. The designer does not assume any liability for structural integrity in the designs. The company selected to build the Designs will assume all liability to its structural integrity and related consumer, crew and performer safety.

Brandon M. Newton
Scenic Designer Signature

PAINT ELEVATION - TELEPHONE BOOTH
 - SATIN FINISH
 - WRAP FACING TEXTURE ONTO ADJACENT SIDES

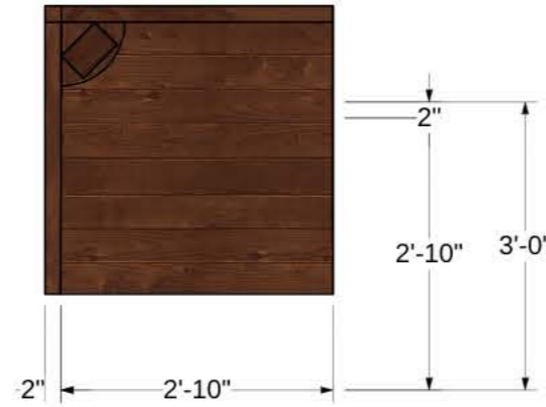

TELEPHONE BOOTH TOP VIEW



TELEPHONE BOOTH
BACK VIEW

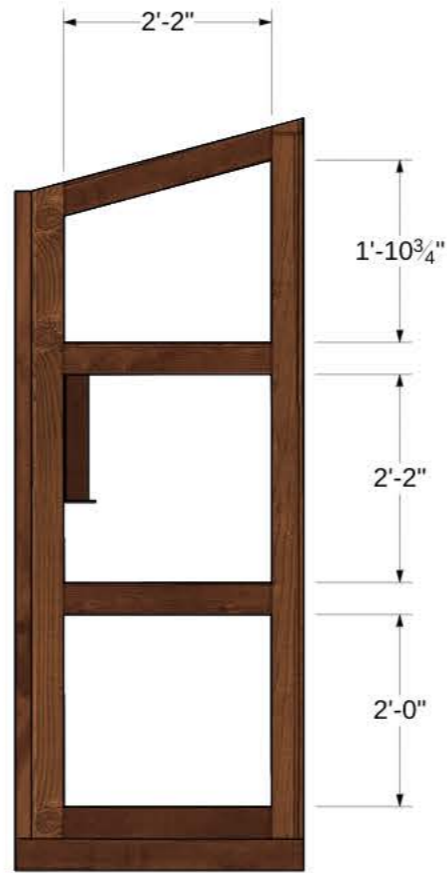

TELEPHONE BOOTH
LEFT VIEW

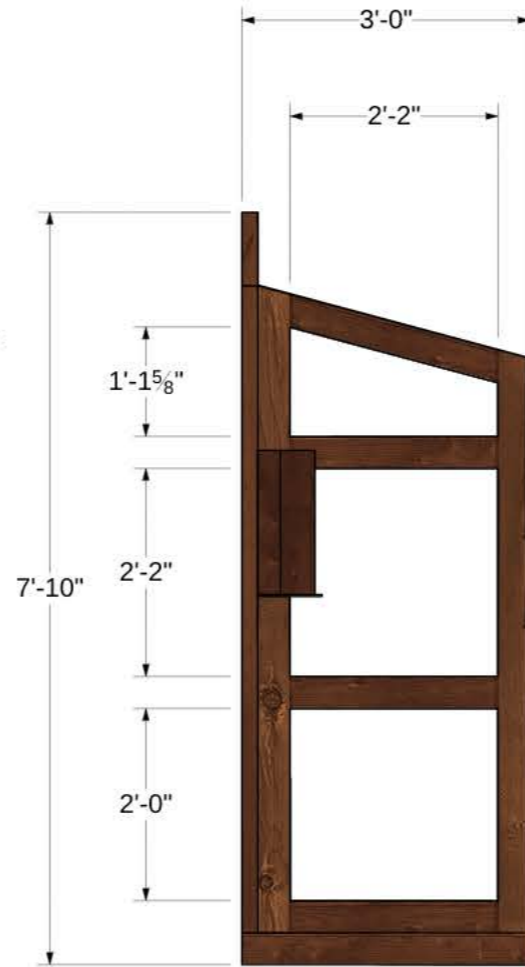

TELEPHONE BOOTH
FRONT VIEW

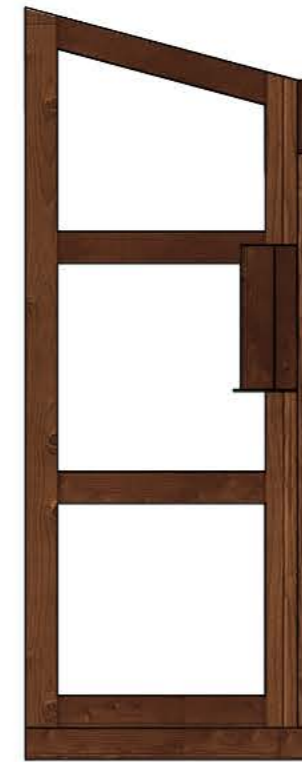

TELEPHONE BOOTH
RIGHT VIEW

<p>Disclaimer: Drawings are only meant only to illustrate ideas and are not to be used for construction. The designer does not assume any liability for structural integrity in the designs. The company selected to build the designs will assume all liability to its structural integrity and related consumer, crew and performer safety.</p>	
<p>Venue: Jeanine Larson Dobbins Conservatory</p>	
<p>Stage: Bedell Theatre</p>	
<p>Director: Kitt Lavoie</p>	
<p>Charge Artist: Brandon M. Newton</p>	
<p>Scenic Designer Signature: <i>Brandon M. Newton</i></p>	
<p>GUYS & DOLLS</p>	
<p>Sheet Title: Paint Elevation - Telephone Booth</p>	
<p>Date: July 14, 2021</p>	<p>Scale: 1" = 1'-0"</p>
<p>Designer: Brandon M. Newton</p>	<p>Drawn By: Brandon M. Newton</p>
<p>Sheet Number: ELE-17</p>	
<p>of: 22</p>	

PAINT ELEVATION - FOOTLIGHTS AND STREETLIGHTS

- STREETLIGHTS HAVE METALLIC BASE
- STREETLIGHTS HAVE ATIN FINISH
- FOOTLIGHTS HAVE MATTE FINISH
- WRAP TEXTURE ONTO ALL APPROPRIATE ADJACENT SIDES

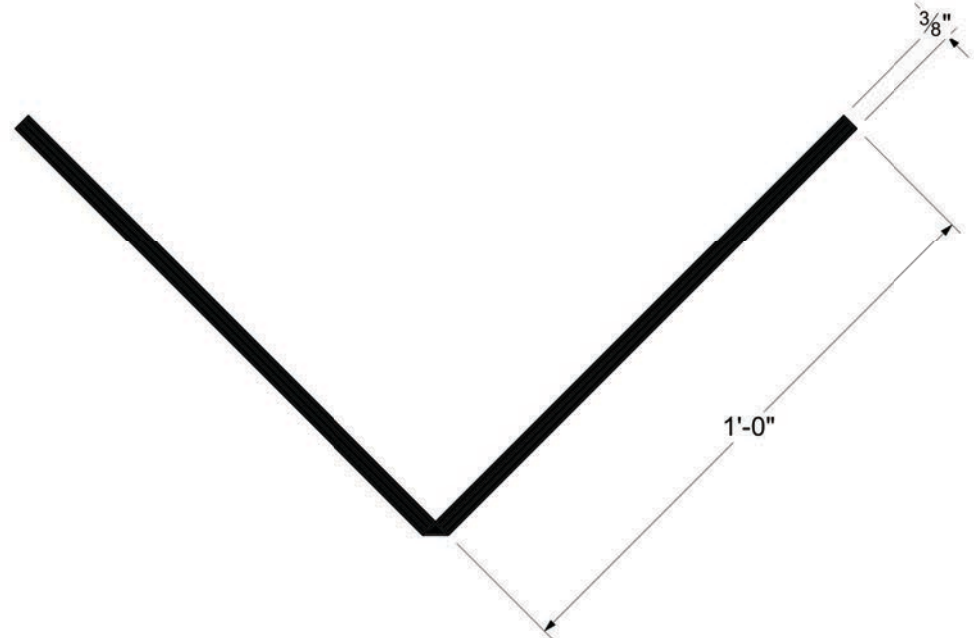

FOOTLIGHTS TOP VIEW

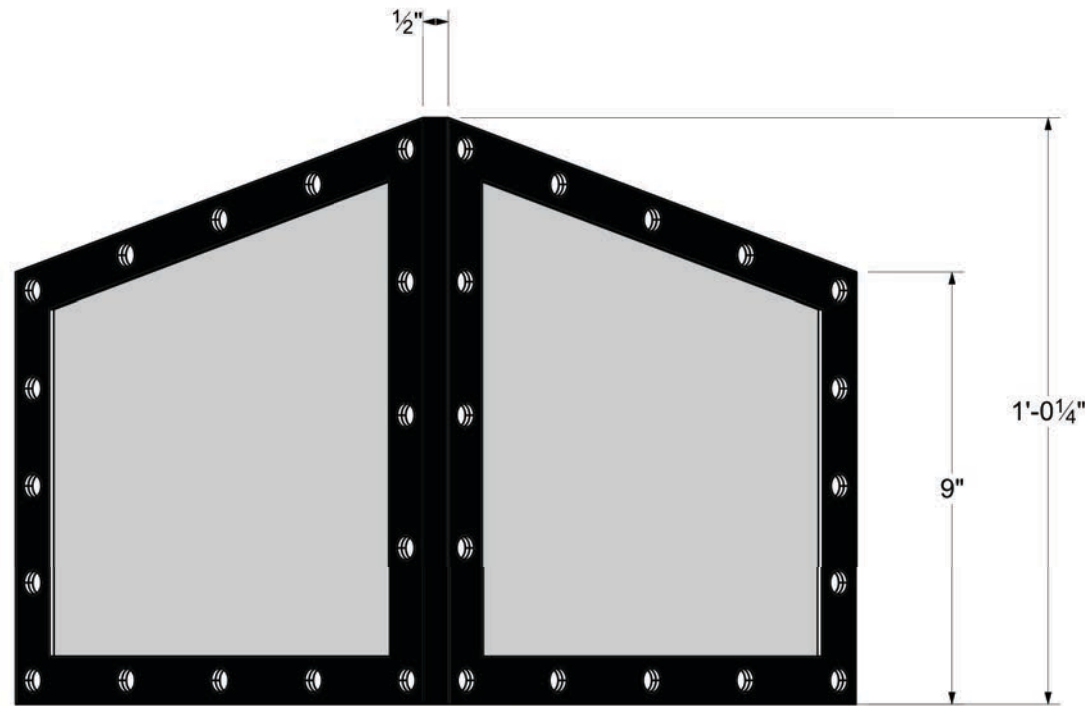

FOOTLIGHTS (FRONT VIEW)
SCALE: 3" = 1'-0"
QTY: 9



NYC STREETLIGHT
SCALE: 1" = 1'-0"
QTY: 3

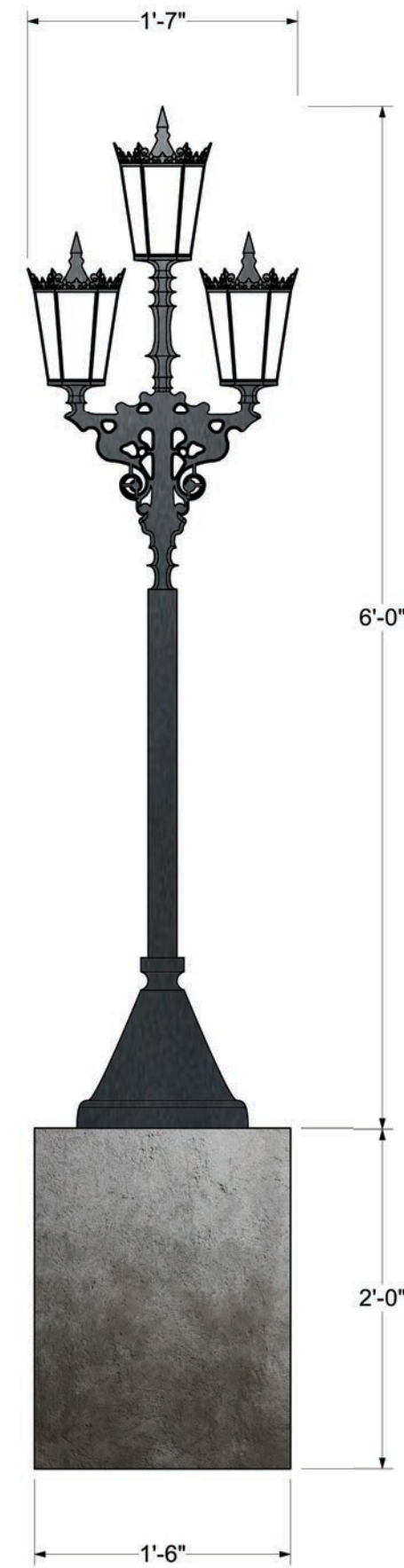

HAVANA STREETLIGHT
SCALE: 1" = 1'-0"
QTY: 3

Disclaimer:
Drawings are only meant only to illustrate ideas in a project. They are not to be used for construction or other purposes without the approval of the designer. The designer does not assume any liability for structural integrity in the designs. The company selected to build the designs will assume all liability to its structural integrity and related consumer, crew and performer safety.

Scenic Designer Signature
Brandon M. Newton

Venue:	Jeanine Larson Dobbins Conservatory
Stage:	Bedell Theatre
Director:	Kitt Lavoie
Charge Artist:	Brandon M. Newton

GUYS & DOLLS

Sheet Title:	Paint Elevation - Footlights & Street Lights
Date:	July 14, 2021
Scale:	Varies
Designer:	Brandon M. Newton
Drawn By:	Brandon M. Newton

Sheet Number:
ELE-18
of 22